

MASTER

inverter monoblock heat pump

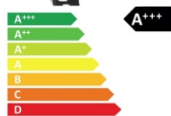

MASTER is a high efficiency reversible air to water heat pump. It is a fully integrated unit, where the indoor and outdoor units are combined as one module.

This unit does not require refrigerant piping work since the monoblock outdoor unit is connected exclusively to water piping.

It is equipped with DC inverter compressor, DC brushless fan motor, and hydronic kit with DC inverter circulator. The inverter technology together with the effective modulating power ensure very high efficiency. These features ensure high COP and EER.

All models have function of heating and cooling, can produce domestic hot water, are WiFi ready and can be controlled remotely.

It is available in two versions: MASTER with R32 refrigerant, and MASTER PLUS with R290 refrigerant.



R32 / R290 refrigerant



Axial fan with speed inverter



Twin-rotary Mitsubishi compressor



Installation and PV control



Domestic hot water production



Low noise operation

Main features

- All units can work in three different modes: heating, cooling and DHW, with specific programs that enhance the performance at all conditions, with ambient temperature curve management
- Energy class A+++ , cutting edge technology and modern design
- Wide range of working temperature: ambient temperature -25..+45°C, and water output temperature 10...75°C
- All models series are WiFi ready and can be controlled remotely by smartphone application
- Twin-rotary DC **Mitsubishi** Inverter compressor and axial fan with DC inverter motor
- EEV (Electronic expansion valve) technology for precise control of the refrigeration cycle
- Source exchanger: Optimized circuit with blue fin coil and copper pipes
- Brazed heat exchanger for the hydraulic circuit with reduced pressure drop on the water side
- Refrigerant circuit: The circuit is made with copper pipes and includes: condensing control, electronic expansion valve (EEV), reversing valve for heating/cooling, high/low pressure switch, separator and liquid receiver, drainage valve, high and low pressure transducers, discharge/suction/coiling temperature sensor
- Integral hydraulic system: pump with high efficiency brushless circulator, expansion tank, water flow sensor, air valve, pressure relief valve, water inlet/outlet temperature sensor
- Intuitive controller with various functions for the complete hydraulic installation: buffer, HUW boiler, solar thermal panel, up to two diverting valves, one mixing valve, and two installation pumps
- Energy state (smart grid), connection with the PV installation, energy information monitoring

REFRIGERANT



The MASTER heat pump is using R32 refrigerant, which has 70% lower GWP (global warming potential) compared to older types of refrigerant, and can reach output temperature up to 60°C.

The new range of heat pumps is available with R290 refrigerant, which is pure propane and has a very low environmental impact and can reach temperature up to 75°C.

R290 is the preferred hydrocarbon alternative of the Environmental Protection Agency (EPA).

HIGH EFFICIENCY

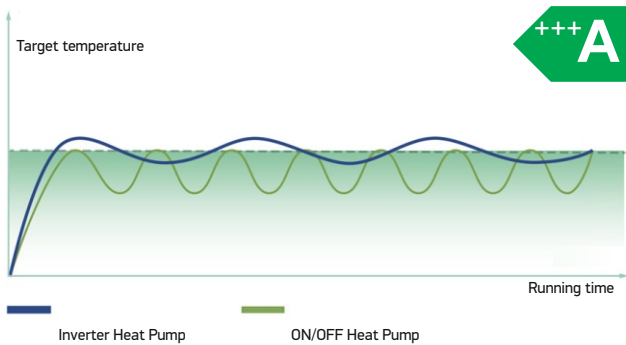

The heat pump is in compliance with ErP directives and attains the A+++ energy class.

Due to the full inverter technology of the compressor and fan, it can modulate to low frequency when set temperature is reached in order to maintain minimum heat losses of the house.

This ensures shorter heating time, smaller temperature fluctuations, and significant energy savings.

COMPONENTS



MITSUBISHI COMPRESSOR

The compressor is the heart of the heat pump for efficiency and reliability. It ensures stable heating capacity and reduced noise.

All MASTER heat pumps come with DC inverter twin-rotary **Mitsubishi** compressor.

EVI TECHNOLOGY

EVI stands for “Enhanced Vapor Injection” and is a technology used to achieve higher performance at lower temperatures as low as -25°C.

EVI -25°C



DC BRUSHLESS FAN

The fan motor is DC brushless to ensure improved efficiency.

Also, the fan blades and the air grill are specially designed to ensure as low noise as possible.



EEV EXPANSION VALVE

The expansion valve is with electric control (EEV). This feature, combined with precision measuring of refrigerant temperature and pressure, ensure optimum efficiency.



PLATE HEAT EXCHANGER

The plate heat exchanger is carefully selected to increase heat transfer efficiency, low pressure drop, and ensure higher COP.



DC INVERTER PUMP

The heat pump comes with reliable DC inverter pump, to ensure reliability and comfortable heating experience.

CONTROLLER

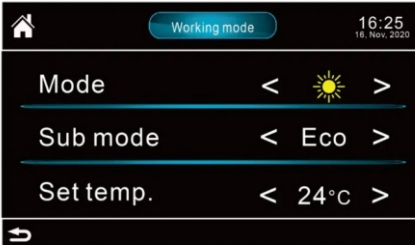
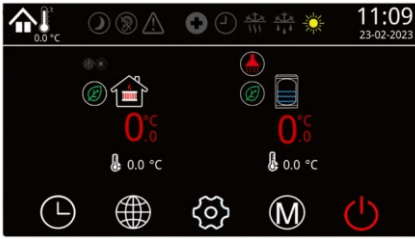

The heat pump is equipped with a 5 inch colour touch screen, which is very intuitive and user-friendly, and has shows the power consumption daily, monthly and yearly.

- Premium design 5 inch colour LCD display
- Capacitive touch button
- Information with simple graphic icon and text
- Energy consumption and heat production monitoring daily, monthly, yearly
- Integrated control of a hot water boiler / buffer
- Room thermostat connection for heating / cooling
- Integrated weekly programmer
- WiFi ready and control through smartphone application
- Cascade of 2 heat pumps with standard controller, up to 8 heat pumps with a cascade module (optional)
- Control of the complete heating installation with 7 sensors: external temperature, buffer tank, DHW tank (low and high), internal room sensor, solar circuit, heating circuit.

SG READY AND SMART GRID

The heat pump can receive signals about the power source and switch energy usage. When the electricity price is high, the heat pump runs as energy-saving as possible, when the price is low, it will use as much electricity as possible.

It can also be connected with the solar photovoltaic installation, and adjust its power consumption to the energy production.



REMOTE CONTROL AND CLOUD PLATFORM

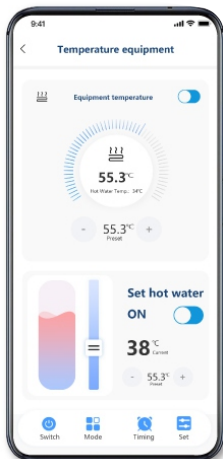

The heat pump has integrated Wi-Fi function and mobile application, so that the user can control the heat pump anywhere and anytime.

The application has highly integrated control functions, is easy to operate and transforms your heating installation into a truly smart operating system.

Additionally, the producer can use the smart data platform to provide remote product inspection, and even software update, offering prompt assistance.

INSTALLATION SCHEME

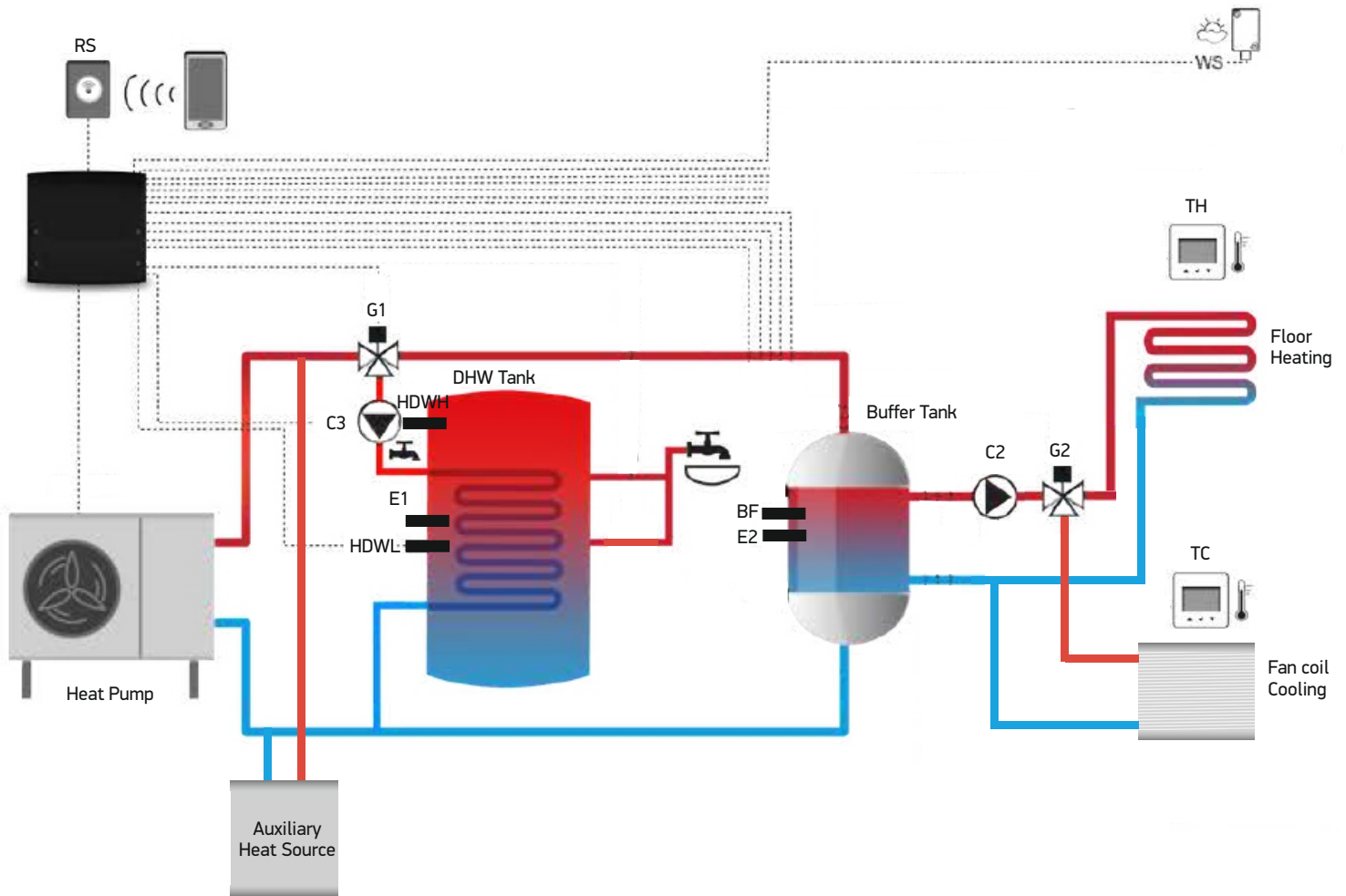

Legend:

G1: 3-way diverting valve for heating/DHW
 G2: 3-way diverting valve for heating/cooling
 C2: Internal installation pump
 C3: DHW pump
 TH: Heating room thermostat
 TC: Cooling room thermostat
 BF: Buffer sensor

HDWH: DHW sensor (high)
 HDWL: DHW sensor (low)
 E1: DHW electric heater
 E2: Buffer electric heater
 WS: External temperature sensor
 RS: Room temperature sensor

SUPER LOW NOISE

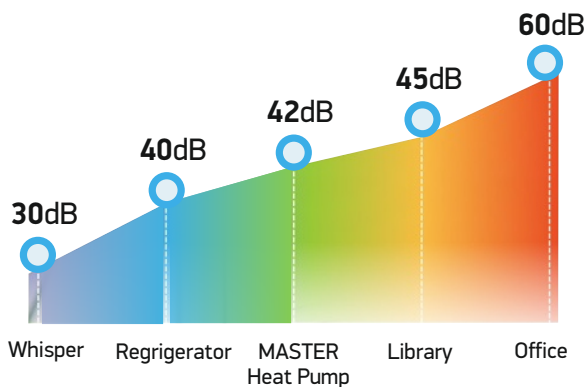

The heat pump is equipped with super quiet full DC inverter compressor and full DC inverter fan motor system to ensure super low noise. The sound levels start as low as 42dB(A), making itself the quietest system in our DC inverter lineup.

Meanwhile, it could provide a special silent mode which could be even more silent for the user and the neighbours.

TECHNICAL DATA MASTER (R32)

Type		MASTER 60	MASTER 90	MASTER 120	MASTER 160	MASTER 180	MASTER 120T	MASTER 160T	MASTER 180T	MASTER 260T	
Heating capacity range		kW	1,5-7	2-10	3-13	4-18	4-20	3-13	4-18	4-20	5-28
A 7°C W 30/35°C	Heating capacity	kW	6,2	9,2	12,1	16,1	18,1	12,1	16,1	18,1	26,1
	Power input	kW	1,34	1,96	2,63	3,58	4,00	2,62	3,58	3,98	5,79
	Current	A	5,82	8,52	11,44	15,56	17,39	4,42	6,04	6,72	9,77
	COP	W/W	4,63	4,69	4,60	4,50	4,53	4,62	4,50	4,55	4,51
A 7°C W 47/55°C	Heating capacity	kW	6,2	9,1	11,0	16,1	17,1	11,1	16,0	17,1	25,3
	Power input	kW	2,2	3,14	4,05	5,37	5,90	4,05	5,33	5,90	7,93
	COP	W/W	2,82	2,90	2,72	3,00	2,90	2,74	3,00	2,90	3,18
A 35°C W 23/18°C	Cooling capacity	kW	6,0	9,1	11,0	15,1	17,2	11,0	15,1	17,2	23,9
	Power input	kW	1,57	2,36	2,88	3,96	4,51	2,86	3,96	4,50	6,26
	EER	W/W	3,82	3,85	3,82	3,81	3,81	3,85	3,81	3,82	3,82
A 35°C W 12/7°C	Cooling capacity	kW	6,2	8,5	10,7	14,5	16,3	10,7	14,5	16,3	22,2
	Power input	kW	2,10	2,85	3,63	4,78	5,78	3,58	4,78	5,75	7,49
	EER	W/W	2,95	2,98	2,95	3,03	2,81	2,99	3,03	2,83	2,97
Rated water flow		m ³ /h	1,1	1,6	2,1	2,8	3,1	2,1	2,8	3,1	4,5
Rated power supply		V/Hz	~220-240/50					~380-415/50			
Max input power		kW	2,2	3,5	4,7	6,0	6,6	4,7	6,5	6,5	10,0
Max input current		A	12	15	20	26	28	8	11	11	17
Refrigerant		-	R32								
Air flow		m ³ /h	3.500	4.000	4.500	6.500	8.000	4.500	6.500	8.000	9.000
Waterproof grade		-	IPX4								
Noise level (1m/5m)		dB	51/37	53/39	54/40	56/42	56/42	54/40	56/42	56/42	58/44
Max water outlet temp.		°C	60								
Water connections		inch	1"	1"	1"	1"	1"	1"	1"	1"	1 ½"
Drainage valve		inch	½"	½"	½"	½"	½"	½"	½"	½"	½"
Water pressure drop		kPa	22	40	50	50	50	50	50	50	50
Min/Max water pressure		bar	0,5/3,0								
Fuse (PCB)		A	15								
Min/Max ext. temp. (heating)		°C	-20/45								
Min/Max ext. temp. (cooling)		°C	15/45								
Dimensions	Length	mm	976	1106	11065	1106	1106	1106	1106	1106	1106
	Width	mm	450	450	450	450	450	450	450	450	450
	Height	mm	688	688	835	1135	1603	835	1135	1603	1603
Weight (empty)		kg	65	75	85	100	135	75	100	135	180

TECHNICAL DATA MASTER PLUS (R290)

Type		MASTER PLUS 60	MASTER PLUS 90	MASTER PLUS 120	MASTER PLUS 160	MASTER PLUS 120T	MASTER PLUS 160T		
Heating capacity range		kW	1,5-7	2-10	3-13	4-18	3-13	4-18	
A 7°C W 30/35°C	Heating capacity	kW	6,2	9,2	12,1	16,2	12,1	16,2	
	Power input	kW	1,36	2,02	2,67	3,58	2,66	3,56	
	Current	A	5,91	8,83	11,43	15,26	4,41	5,89	
	COP	W/W	4,56	4,55	4,53	4,52	4,55	4,55	
A 7°C W 40/45°C	Heating capacity	kW	6,1	9,1	12,0	16,0	12,0	16,0	
	Power input	kW	1,71	2,51	3,35	5,02	3,30	4,98	
	COP	W/W	3,58	3,62	3,59	3,19	3,65	3,22	
A 7°C W 47/55°C	Heating capacity	kW	6,1	9,1	12,0	16,0	12,0	16,0	
	Power input	kW	2,07	3,06	4,15	5,56	4,05	5,43	
	COP	W/W	2,95	2,97	2,89	2,90	2,99	2,97	
A 35°C W 23/18°C	Cooling capacity	kW	6,3	9,1	11,3	15,1	11,3	15,2	
	Power input	kW	1,62	2,33	2,95	3,96	2,91	3,98	
	EER	W/W	3,89	3,87	3,83	3,81	3,88	3,82	
A 35°C W 12/7°C	Cooling capacity	kW	6,2	8,6	10,6	15,1	10,6	15,1	
	Power input	kW	2,1	2,92	3,58	5,26	3,58	5,26	
	EER	W/W	2,95	2,95	2,96	2,86	2,96	2,86	
Rated water flow		m³/h	1,1	1,6	2,1	2,8	2,1	2,8	
Rated power supply		V/Hz	~220-240/50				~380-415/50		
Max input power		kW	2,2	3,5	4,7	6,0	4,7	6,5	
Max input current		A	12	15	20	28	8	11	
Refrigerant		-	R290						
Air flow		m³/h	3.500	4.000	4.500	8.000	4.500	8.000	
Waterproof grade		-	IPX4						
Noise level (1m/5m)		dB	51/37	53/39	54/40	56/42	54/40	56/42	
Max water outlet temp.		°C	75						
Water connections		inch	1"	1"	1"	1"	1"	1"	
Drainage valve		inch	½"	½"	½"	½"	½"	½"	
Water pressure drop		kPa	22	40	50	50	50	50	
Min/Max water pressure		bar	0,5/3,0						
Fuse (PCB)		A	15						
Min/Max ext. temp. (heating)		°C	-25/45						
Min/Max ext. temp. (cooling)		°C	15/45						
Dimensions	Length	mm	976	1106	1106	1106	1106	1106	
	Width		450	450	450	450	450	450	
	Height		688	688	835	1603	835	1603	
Weight (empty)		kg	70	80	90	160	90	160	